

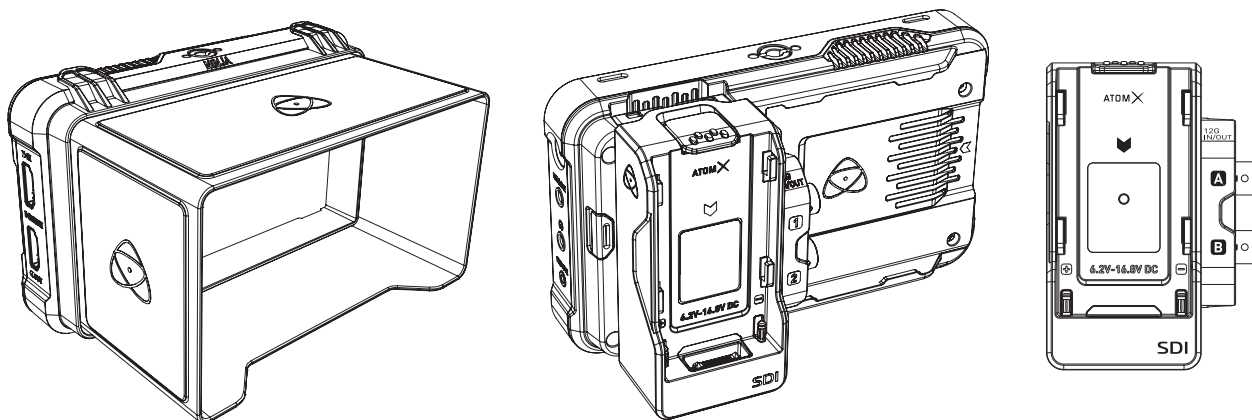

NINJA V+ PRO KIT

5" 8Kp30 4Kp120 1000nit HDR HDMI Monitor Recorder



Key Features

- Capture without limitation in RAW at up to 8Kp30
- Continuous HFR recording up to 120p in ProRes RAW
- 1000nit 5" HDR display with AtomHDR support for Log inputs and 3D LUTS
- Hardware that grows with your needs via the AtomX expansion for additional connectivity and wireless SYNC
- Flexibility of codec choice from ProRes RAW, ProRes, DNx, H.265
- Playback provides 3 simultaneous outputs via 2 x 12G SDI out and 1 x HDMI in 10-bit up to 4Kp60
- HDMI ↔ SDI signal cross conversion with option 4K to HD Down convert
- Connect to your DTap power source with the locking DTap cable and Battery Eliminator

The Ninja V+ Pro Kit has been designed to bridge the gap between compact cinema and mirrorless cameras that can output RAW via HDMI or SDI. With all the power of the V+ for 8Kp30 the Pro Kit adds the addition of 4Kp120 and 2Kp240 continuous recording via SDI.

The Ninja V+ takes advantage of new Atomos Silicon AtomIC3, AtomOS 10 and the incredible efficiency of ProRes RAW to deliver these increased resolutions and frame rates. The new formats also integrate seamlessly into the timeline of your existing ProRes RAW or ProRes projects, without huge storage or processing overheads.

Ninja V+ Pro Kit and 4Kp120

To support SDI users, the Ninja V+ Pro Kit comes packed with camera accessories and enables 4Kp120 ProRes RAW recording mode from the SDI RAW output of the Sony, FX9* and FX6*. Both Atomos and Sony users will now be able to experience the benefits of working with images at a high frame rate and resolutions, whilst recording in pristine ProRes RAW.

Professional Accessories

Combined with the AtomX SDI module and some serious tuning under the hood, the Pro Kit provides the ability to record RAW over SDI from some of the best compact cinema cameras on the market. No RAW, no problem. The Ninja V+ monitor-recorder is a flexible tool that can work as a HDMI/SDI ProRes monitor-recorder.

Worry less when it comes to battery management and excess weight as the Pro Kit is designed to be powered via DTap from your camera battery or rig, and can also use a battery eliminator for studio power. Pro Kit also includes a AtomX 5" Sunhood providing increased monitoring options outdoors and reduced ambient light for when monitoring in HDR.

SDI - Powerful & Versatile I/O

Adding dual 12G SDI connectivity expands the compatibility with other cameras to provide off board 10-bit 422 recording in edit ready codecs or as proxy files from RED or ARRI cameras allowing the file naming and timecode to also be applied to the recorded files. And of course, the Ninja V+ also provides support for RAW over HDMI from our ever-growing roster of mirrorless cameras including the Sony Alpha 7S III, Z CAM E2 Series, Nikon Z Series, LUMIX S Series, Olympus OM-D EM-1X, Olympus OM-D M1 MkIII and more.

The Flexibility to Suit any Production

In playback mode the Ninja V+ Pro Kit provides a lossless signal distribution with 2 x 12G SDI and 1 x HDMI 2.0 for simultaneous outputs up to 4K p60. When used in combination with the Ninja's playlist functionality it provides a fast and convenient way to review content or show a highlight reel. RAW inputs can also be de-bayered in real time and non-standard high resolutions are processed to SMPTE standard output formats. Convert to HLG, PQ or your choice of 3D LUT can also be applied allowing for RAW or LOG content to be viewed with the correct application of artistic intent.

The Pro Kit Offers 3 Ways to Power Your Ninja V+

- In the Studio you can use the included DC power supply with lockable jack to connect to the Ninja V+ and with the international power plugs you'll be covered wherever your work might take you.
- On-set via the included DTap cable to connect to your choice of battery with a DTap output meaning your camera rig can run from a single power source.
- On the move with a compact rig you also have the choice to run the Ninja directly from an optional NPF battery or any 4 cell NPF you might have in your kit bag.

Price

US\$1,699 ex. tax | €1,699 ex. tax

SKU: ATOMNJVPL2
UPC: 814164022606

NINJA V+ PRO KIT - Technical specifications

Physical Specifications	
Weight (Monitor Only)	360g / 12.7oz
Dimensions (Monitor Only)	151 x 91.5 x 31mm
Mount Points	1 x Anti rotation 1/4" / 3/8 top and bottom
Construction	
Body	Aluminium with ABS plastic
Cooling	Active
Tally Light	Record Tally on rear
AtomXpansion Slot	Yes
Power	
Input voltage (battery)	6.2V to 16.8V
Operating Power	5.8-7.2v
Compatible Batteries	NPF L series
Battery Run Time	5200mAh - up to 2hrs (monitor & record 4K 60p) 7800mAh - up to 3hrs (monitor & record 4K 60p)
DC In	via Battery eliminator
Display	
Touchscreen	SuperAtom IPS panel (capacitive touch)
Size	5"
Resolution	1920 x 1080
PPI	427
Bit Depth	10-bit (8+2 FRC)
Backlight	Edge lit
Aspect Ratio	16:9
Color Gamut	Rec.709
Technology	
AtomHDR Technology	Log to Native / Rec709/ 3D Lut / HLG / PQ
3D LUT Support	Display / Preview / Loop out
HDR Monitoring Technology	HLG and PQ
HDR Output Conversion	Log / HDR to HLG / PQ / Dolby Vision
Gamma	Sony SLog /SLog2 /SLog3, Canon CLog /CLog2 /Clog3, Arri Log CEI160 / LogCEI200 /LogCEI250 /LogCEI320 /LogCEI400 /LogCEI500 /LogCEI640 / LogCEI800 /LogCEI1000 /LogCEI1280 /LogCEI1600, Panasonic Vlog, JVC JLog1, Red LogFilm /Log3G10 /Log3G12, FujiFilm Flog, PQ (HDR10), HLG, Nikon N-Log
Gamut	BT2020, DCI P3, PDCI p3 65, Sony SGamut /SGamut3 /SGamut3.cine /Canon Cinema /DCI P3 /DCI P3+ /BT2020, Panasonic V Gamut, Arri Alexa Wide Gamut, Rec709, JVC LS300, Red DragonColor / DragonColor2 /RedColor2 / RedColor3 / RedColor4 /RedWideGamut
Video Input	
HDMI	1 x HDMI (2.0) 4Kp60
HDMI RAW	Yes
SDI	2 x 12G SDI Backward compatible via included AtomX SDI module
SDI RAW	Yes (NOTE: Sony FS700*, FS5*, FS7* supported from 10.71)
Signal (Camera Dependent)	Uncompressed true 10-bit or 8-bit 422
LTC (Record Mode Only)	Optional Wireless RF via SYNC module
Video Output	
HDMI	1 x HDMI (2.0) 4Kp60
SDI (Play Out)	2 x 12G SDI via included AtomX SDI module - level A and B selectable
Signal	Uncompressed true 10-bit or 8-bit 422 (playback file dependent)
Video Signal Conversion	
HDMI to SDI	Yes - Video and RAW
SDI to HDMI	Yes - Video and RAW
Audio In/Out	
Audio Quality	24/48KHz
Audio Codec	PCM
HDMI	8ch 24-bit, input dependent
SDI	12ch 24-bit, input dependent
Analogue Audio in	3.5mm 2ch.
Headphone out	3.5mm 2ch.
Supported Codecs & Frame Rates (Record & Playback)	
Supported Resolution & FPS	8K RAW Only up to 30p via HDMI 6K: RAW Only up to 30p via HDMI and SDI (Camera dependent 5.9k HDMI and 5.7k SDI) 5K: RAW Only up to 60p via HDMI 4K DCI: 23.98/24/25/29.97/30/50/59.94/60p - HFR 100/120 via RAW over HDMI & SDI on selected cameras 4K UHD: 23.98/24/25/29.97/30/50/59.94/60p 2K DCI: 23.98/24/25/29.97/30/50/59.94/60p / FX9 RAW up to 2K 240p 1080p: 23.98/24/25/29.97/30/50/59.94/60/100/120p 1080i: 50/59.94/60i 720p: 50/59.94/60p PsF - converted to P and looped out PsF

Anamorphic	3.5K: RAW up to 60p (from supported cameras only)
Apple ProRes Raw	ProRes RAW HQ, ProRes Raw
Apple ProRes	ProRes LT, 422, HQ
Avid DNx (Requires Free codec activation)	AVID DNxHR HQX, HQ, SQ, LB
H.265	Yes, recorded clips
Playback	
Playlist / Genlock / LTC	Yes / No / No
Loop	Yes with in and out markers
Playlist	Yes
Apple ProRes Raw	Yes
Apple ProRes	Yes, with Linear PCM audio
Avid DNx (Requires Free codec activation)	Yes, with Linear PCM audio
H.265	Yes, recorded clips
Recording functions & Media	
Pre-roll Record	Yes (HD 8s, 4K 2s) - Not available in RAW
Timelapse	Yes
Media Type	Master Caddy II / SSDmini
File Naming	Scene, Shot, Take / File name via SDI for Arri and RED
Supported Editing applications	All NLE applications that support Apple ProRes, ProRes RAW and Avid DNxHQR/HD in .MOV
On Screen Tools	
Scopes	Luna Waveform RGB Parade Vecor Scope
Magnification	1 x Zoom 2 x Zoom
Focus Peaking	Colour selected / threshold setting / colour / Mono / edges only
False Color	Yes, with scale
Zebra	Yes, adjustable
Isolate Color Channel	Blue Only
Cut Tag Edit markers	Yes, Playback mode
Cine Frame Guides	2.4:1, 2.35:1, 1.9:1, 1.85:1, 4:3
Social Frame guides	9:16, 11, 19:1, 4:5
Safe Areas	Action and Graphic
Grid Markers	9 Grid
Anamorphic Desqueeze	1.25x 1.33x , 1.5x ,1.8x ,2x
Display Flip	Vertical Only
3DLUT 50/50	Yes, on screen preview
Timecode	
HDMI	Yes
SDI	Yes
Time Of Day	Yes
Wireless RF	Optional Via Sync Module
Bluetooth LE	Optional Via Sync Module
Onboard Processing	
Pulldown Removal	24/25/30pSF > 24/25/30p (2:2 pulldown) 60i > 24p (3:2 pulldown)
4K UHD Downscale for HD	Yes - On Loop-out
DCI Crop	Yes - On Loop out
Remote control	
HDMI	Auto HDMI Trigger, Supported Protocols - Canon, Sony, Atomos Open Standard
SDI	SDI trigger camera selectable
LANC 2.5mm Jack	LANC control and calibration via optional USB to serial cable
What's in the box	
Accessories Included	Ninja V + with SDI RAW preactivated, AtomX SDI module, 1x DTap to DC cable, 5" Sunhood, EVA Carry case, 5" Protective Monitor sleeve, Battery Eliminator, International DC power supply, 1x MasterCaddy II and QuickStart Guide
Optional Extras	Power kit, HDMI cables, USB to serial cable, AtomX SYNC module
Warranty	
Standard	1 year. Extended to 3 years on product registration

*FX9 requires XDCA-FX9,
FS7 requires XDCA-FS7 Extension unit.
FS700 and FS5 mki require RAW update
SKU:ATOMNJVPL2
UPC: 814164022606