

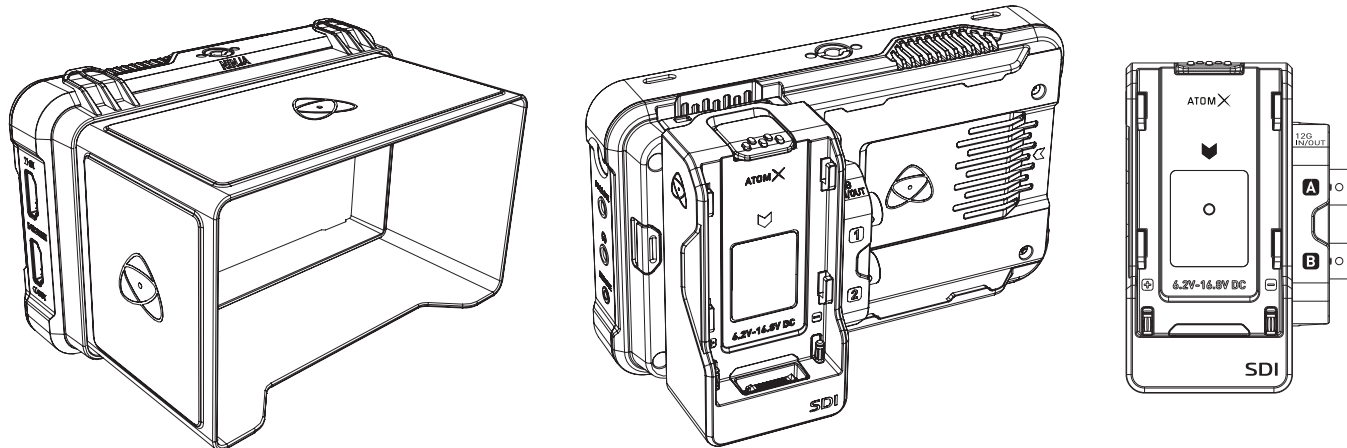

# NINJA V PRO KIT

5" 4Kp60 1000nit HDR Monitor Recorder HDMI & SDI in/out



## Key Features

- Record up to 6K RAW via both HDMI and SDI at up to 12-bit in Apple ProRes RAW.
- Video inputs up to 4Kp60 supported via HDMI or 12G SDI to Apple ProRes or Avid DNx.
- Configurable SDI for single or dual link inputs or toggle between SDI A and B.
- Play out provides 3 simultaneous outputs via 2 x 12G SDI out and 1 x HDMI in 10-bit up to 4Kp60.
- HDMI <=> SDI signal cross conversion with, RAW to Video output option.
- Connect to your DTap power source with the locking DTap cable and battery eliminator.
- AtomX 5" Sunhood provides increased monitoring options and reduced ambient.
- AtomHDR for Log inputs and 3D LUTs.

## Record up to 6K RAW via HDMI and SDI

The Ninja V Pro Kit has been designed to bridge the gap between compact cinema and mirrorless cameras that can output RAW via HDMI or SDI. Pro Kit also pushes the limits of these cameras, recording up to 12-bit RAW externally on the Ninja's onboard SSD. Pro Kit also provides the ability to cross convert signals providing a versatile solution for monitoring and playback/review.

No RAW, no problem. The Ninja V monitor-recorder is a flexible tool that can work as a HDMI/SDI ProRes monitor-recorder. Unify battery management and excess weight as the Pro Kit is designed to be powered via DTap from your camera battery or rig. Pro Kit also includes a AtomX 5" Sunhood providing increased monitoring options outdoors,

and reduced ambient light for when monitoring in HDR.

The robust aluminium 5" monitor-recorder allows for a compact rig set-up for camera owners and operators to work with all the latest cameras. Perfect for run and gun productions, documentary filmmaking and for those close-up shots that require the camera operator to be flexible or mobile.

## The flexibility to suit every application

In playback mode the Ninja V provides a lossless signal distribution with 2 x 12G SDI and 1 x HDMI 2.0 for simultaneous outputs up to 4Kp60. When used in combination with the Ninja's playlist functionality it provides a fast and convenient way to review content or show a highlight reel.

## Accurate and reliable / daylight viewable HDR or SDR

With 1000nits, high pixel density the 5" screen provides clear and accurate monitoring for HDR and SDR. Using the AtomHDR engine the Ninja V provides a managed colour pipeline, matching the camera Gamma and Gamut on the input and select to view this as 709, Log with a 3DLUT or utilize the engine to accurately map the dynamic range of your camera LOG to HLG or PQ HDR standards.

## HDMI-to-SDI cross conversion

Adding the SDI module to the Ninja V platform more than doubles it's I/O functionality. To complement the inputs, HDMI or SDI connections can be cross converted, DCI cropped and 4K to HD down converts for video signals to provide a bridge between equipment such as EVFs, wireless TX/RX without the need for additional converters.

## What's in the box?

Ninja V with SDI RAW Pre-Activated, AtomX SDI module, 1 x Battery eliminator, 1 x international DC power supply, 1 x DTap Cable, 1 x AtomX 5" Sunhood.

## Price

US\$949 ex. tax | €949 ex. tax

# NINJA V PRO KIT - Technical specifications

Physical Specifications	
Weight (Monitor Only)	360g / 12.7oz
Dimensions (Monitor Only)	151 x 91.5 x 31mm
Mount Points	1 x Anti rotation 1/4" / 3/8 top and bottom
Construction	
Body	Aluminium with ABS plastic
Cooling	Active
Tally Light	Record Tally on rear
AtomXpansion Slot	Yes
Power	
Input voltage (battery)	6.2V to 16.8V
Operating Power	5.8-7.2v
Compatible Batteries	NPF L series
Battery Run Time	5200mAh - up to 2hrs (monitor & record 4K 60p) 7800mAh - up to 3hrs (monitor & record 4K 60p)
DC In	via Battery eliminator
Display	
Touchscreen	SuperAtom IPS panel (capacitive touch)
Size	5"
Resolution	1920 x 1080
PPI	427
Bit Depth	10-bit (8+2 FRC)
Backlight	Edge lit
Aspect Ratio	16:9
Color Gamut	Rec.709
Technology	
AtomHDR Technology	Log to Native / Rec709/ 3D Lut / HLG / PQ
3D LUT Support	Display / Preview / Loop out
HDR Monitoring Technology	HLG and PQ
HDR Output Conversion	Log / HDR to HLG / PQ / Dolby Vision
Gamma	Sony SLog /SLog2 /SLog3, Canon CLog /CLog2 /Clog3, Arri Log CEI160 / LogCEI200 /LogCEI250 /LogCEI320 /LogCEI400 /LogCEI500 /LogCEI640 / LogCEI800 /LogCEI1000 /LogCEI1280 /LogCEI1600, Panasonic Vlog, JVC JLog1, Red LogFilm /Log3GI0 /Log3GI2, FujiFilm Flog, PQ (HDR10), HLG, Nikon N-Log
Gamut	BT2020, DCI P3, PDCI p3 65, Sony SGamut /SGamut3 /SGamut3.cine /Canon Cinema /DCI P3 /DCI P3+ /BT2020, Panasonic V Gamut, Arri Alexa Wide Gamut, Rec709, JVC LS300, Red DragonColor / DragonColor2 /RedColor2 / RedColor3 / RedColor4 /RedWideGamut
Video Input	
HDMI	1 x HDMI (2.0) 4Kp60
HDMI RAW	Yes
SDI	2 x 12G SDI Backward compatible via included AtomX SDI module
SDI RAW	Yes (NOTE: Sony FS700, FS5, FS7 <b>NOT</b> supported)
Signal (Camera Dependent)	Uncompressed true 10-bit or 8-bit 422
LTC (Record Mode Only)	Optional Wireless RF via SYNC module
Video Output	
HDMI	1 x HDMI (2.0) 4Kp60
SDI (Play Out)	2 x 12G SDI via included AtomX SDI module - level A and B selectable
Signal	Uncompressed true 10-bit or 8-bit 422 (playback file dependent)
Video Signal Conversion	
HDMI to SDI	Yes - Video and RAW
SDI to HDMI	Yes - Video and RAW
Audio In/Out	
Audio Quality	24/48KHz
Audio Codec	PCM
HDMI	8ch 24-bit, input dependent
SDI	12ch 24-bit, input dependent
Analogue Audio in	3.5mm 2ch.
Headphone out	3.5mm 2ch.
Supported Codecs & Frame Rates (Record & Playback)	
Supported Resolution & FPS	6K: RAW Only up to 30p via HDMI and SDI (Camera dependent 5.9k HDMI and 5.7k SDI) 5K: RAW Only up to 30p via HDMI 4K DCI: 23.98/24/25/29.9/30/50/59.94/60p 4K UHD: 23.98/24/25/29.9/30/50/59.94/60p 2K DCI: 23.98/24/25/29.9/30/50/59.94/60p / FX9 RAW up to 180p 1080p: 23.98/24/25/29.9/30/50/59.94/60/100/120p 1080i: - 23.98/24/25/29.9/30/50/59.94/60i 720p: 50/59.94/60p PsF - converted to P and looped out PsF

Anamorphic	3.5K: RAW up to 60p (from supported cameras only)
Apple ProRes Raw	ProRes RAW HQ, ProRes Raw
Apple ProRes	ProRes LT, 422, HQ
Avid DNx (Requires Free codec activation)	AVID DNxHR HQX, HQ, SQ, LB
Playback	
Playlist / Genlock / LTC	Yes / No / No
Loop	Yes with in and out markers
Playlist	Yes
Apple ProRes Raw	Yes
Apple ProRes	Yes, with Linear PCM audio
Avid DNx (Requires Free codec activation)	Yes, with Linear PCM audio
Recording functions & Media	
Pre-roll Record	Yes (HD 8s, 4K 2s) - Not available in RAW
Timelapse	Yes
Media Type	Master Caddy II / SSDmini
File Naming	Scene, Shot, Take / File name via SDI for Arri and RED
Supported Editing applications	All NLE applications that support Apple ProRes, ProRes RAW and Avid DNxHDR/HD in .MOV
On Screen Tools	
Scopes	Luna Waveform RGB Parade Vecor Scope
Magnification	1 x Zoom 2 x Zoom
Focus Peaking	Colour selected / threshold setting / colour / Mono / edges only
False Color	Yes, with scale
Zebra	Yes, adjustable
Isolate Color Channel	Blue Only
Cut Tag Edit markers	Yes, Playback mode
Cine Frame Guides	2.4:1, 2.35:1, 1.9:1, 1.85:1, 4:3
Social Frame guides	9:16, 11, 1911, 4:5
Safe Areas	Action and Graphic
Grid Markers	9 Grid
Anamorphic Desqueeze	1.25x 1.33x, 1.5x, 1.8x, 2x
Display Flip	Vertical Only
3DLUT 50/50	Yes, on screen preview
Timecode	
HDMI	Yes
SDI	Yes
Time Of Day	Yes
Wireless RF	Optional Via Sync Module
Bluetooth LE	Optional Via Sync Module
Onboard Processing	
Pulldown Removal	24/25/30pSF > 24/25/30p (2:2 pulldown) 60i > 24p (3:2 pulldown)
4K UHD Downscale for HD	Yes - On Loop-out
DCI Crop	Yes - On Loop out
Remote control	
HDMI	Auto HDMI Trigger, Supported Protocols - Canon, Sony, Atomos Open Standard
SDI	SDI trigger camera selectable
LANC 2.5mm Jack	LANC control and calibration via optional USB to serial cable
What's in the box	
Accessories Included	Ninja V with SDI RAW Pre-Activated, AtomX SDI module, 1 x Battery eliminator, 1 x international DC power supply, 1 x Dtap Cable, 1 x AtomX 5" Sunhood
Optional Extras	Power kit, HDMI cables, USB to serial cable, AtomX SYNC module
Warranty	
Standard	1 year. Extended to 3 years on product registration

**Please note:** Specifications are subject to change without notice. All information correct at time of publishing.